

**PE1** PELLET

PELLET BOILER



**UNIQUE. INNOVATIVE.**

Advanced technology for  
pellet boilers



APPROVED FOR  
INSTALLATIONS  
IN ALL PROVINCES



BETTER HEATING

INNOVATIVE AND  
COMFORTABLE

**froling** 

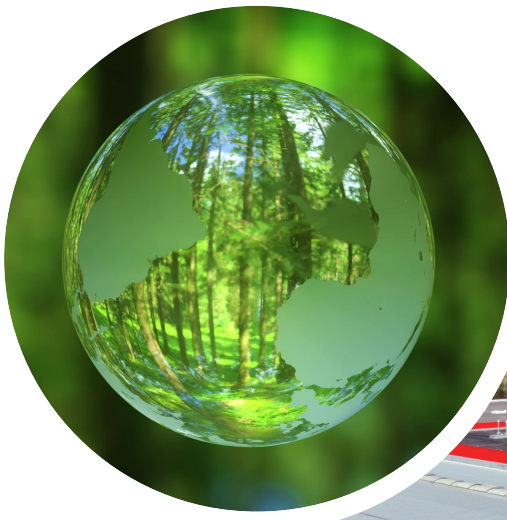

---

## ENVIRONMENTALLY RESPONSIBLE HEATING, ECONOMICALLY ATTRACTIVE

---

The price changes for different energy sources in recent years show the benefits of wood pellets: the ecological way of heating is also economically attractive. Wood is a renewable energy source that is also CO<sub>2</sub>-neutral. Pellets are made of natural wood. The large volumes of wood shavings and sawdust generated by the wood-processing industry are compacted and pelleted without being treated beforehand. Pellets have a high energy output and are easy to deliver and store. These are just some of the advantages that make pellets the perfect fuel for fully automatic heating systems. Pellets are delivered by tanker and unloaded directly into your store.





---

**BIO THERMIC:**  
THE TEAM FOR END-TO-END  
WOOD ENERGY SYSTEMS

---

Biothermic was founded in 2013 and is sought out for its expertise, knowledge and wide range of quality products and services. With over 200 biomass boilers placed across the country, Biothermic offers consulting and design services and supply of Fröling biomass boiler systems. Mike and Vince Rutter, brothers with backgrounds in forestry, physics, business development and natural resource management are the heart of Biothermic. Wood energy is quickly becoming the most affordable and sensible way to save heating costs while reducing carbon emissions. Biothermic will work with you to develop a project from initial analysis to design and through to installation and commissioning.

Western Canada and Northern Ontario  
349 Mooney Ave, Thunder Bay, ON  
(807) 355-5519 | Vince@biothermic.ca

Central Ontario, Quebec and the Maritimes  
1038 Danmarka Tr., Minden, ON., K0M 2K0  
(705) 455-2314 | Mike@biothermic.ca

---

# PELLETS BOILER PE1 PELLET

---

Speed-controlled, quiet induced-draught fan with function monitor

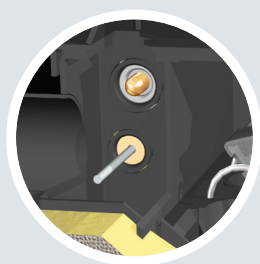

Broadband lambda probe for optimal combustion

WOS system Efficiency Optimisation System

High-quality pellet burner

High-quality insulation

Automatic sliding grate for ash removal

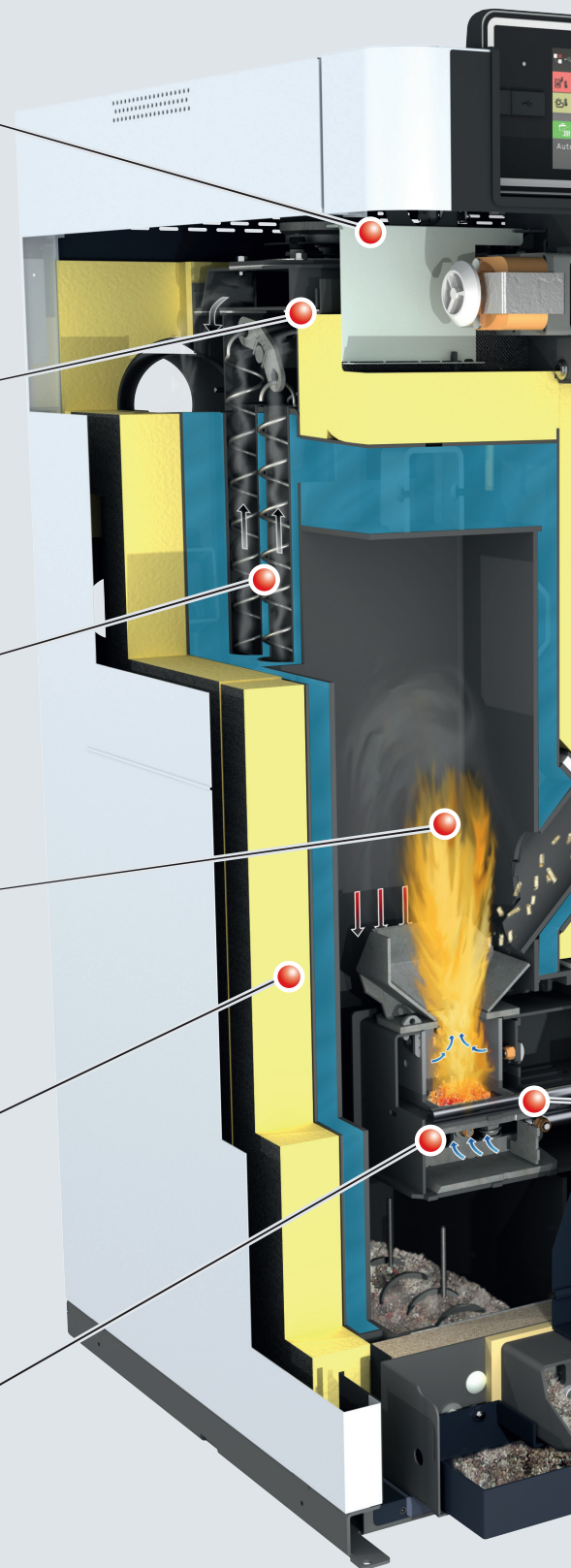

---

# THE LATEST TECHNOLOGY

---

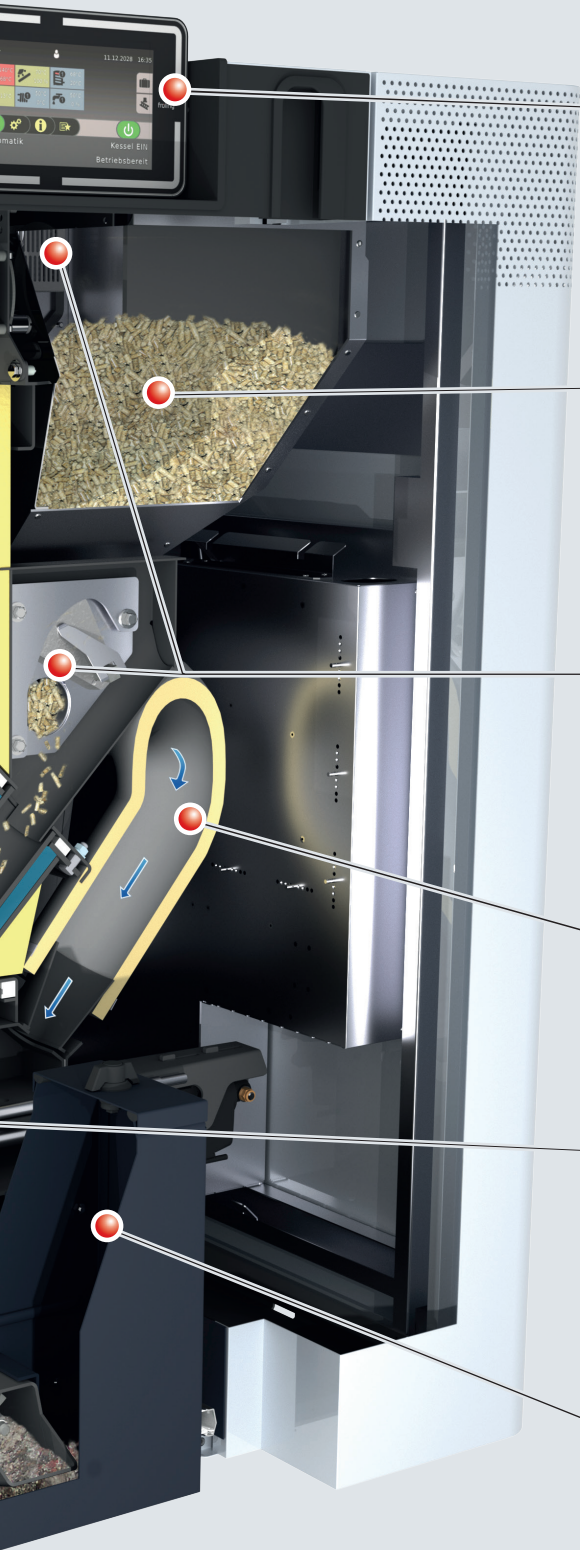

7" touch display for easy and intuitive operation

Generously dimensioned pellet container

Double protection system  
for maximum burn back protection

Combustion air supply  
(optional independent of ambient air)

Automatic ignition

Automatic ash removal in a closed ash container  
(Ash container volume: 28 litres with 20 - 35 kW).

---

# A WELL- DESIGNED INSIDE

---

## Automatic ignition

The new glow ignition is particularly suitable for low boiler outputs. As it is operated without an additional blower fan, the glow ignition is extremely quiet and saves a lot of energy.

- Advantages:
- Quiet operation
  - Low energy consumption

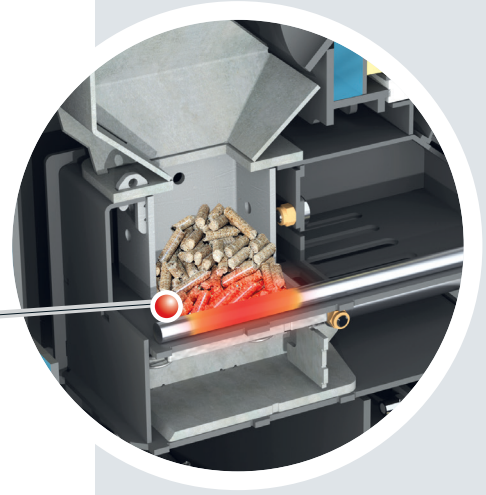

## Pellet burner with automatic sliding grate

The burner is perfectly matched to the fuel pellets and their requirements and enables particularly high levels of efficiency. The sliding grate ensures automatic ash removal in the large ash drawer.

- Advantages:
- High efficiency
  - Automatic ash removal

Open sliding grate

Closed sliding grate

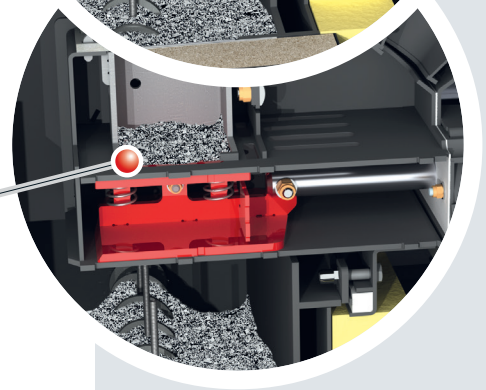
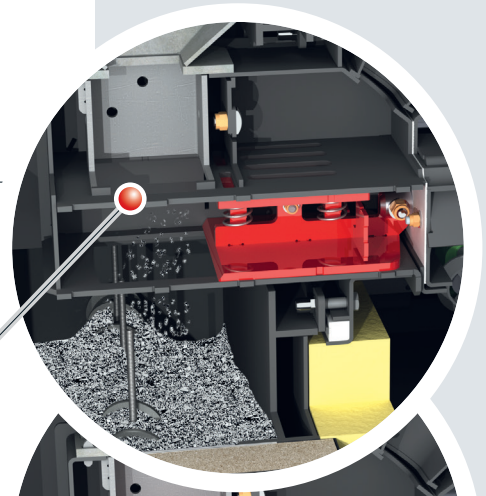

## Comfort ash removal

We never compromise on convenience. The ash that accumulates is automatically conveyed into the large ashcan where it can be easily emptied. The ash removal takes place automatically in a closed ash container by means of an ash screw.

- Advantages:
- Long emptying intervals
  - Convenient emptying

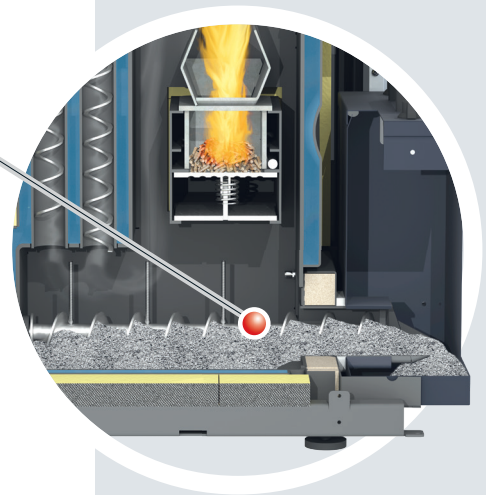



### Gate valve storage room

If fuel is transported from the storage room to the pellet container, the gate valve storage room opens. The gate valve burner is closed at the same time.

### Large pellet container

The large pellet container with a capacity of 32 - 76 L (depending on output size) reduces the frequency of pellet feed. The pellet container is filled fully automatically with an external suction turbine.

- Advantages:
- Easy loading
  - Efficient operation



### Gate Valve Burner

In this way the double protection system ensures a reliable closure between the store and the pellet burner, guaranteeing maximum burn back protection.

### Double protection system

The gate valve storage room and gate valve burner result in a double lock system and thus ensure maximum operational safety.

- Advantages:
- The highest possible operating safety
  - Maximum burn back protection

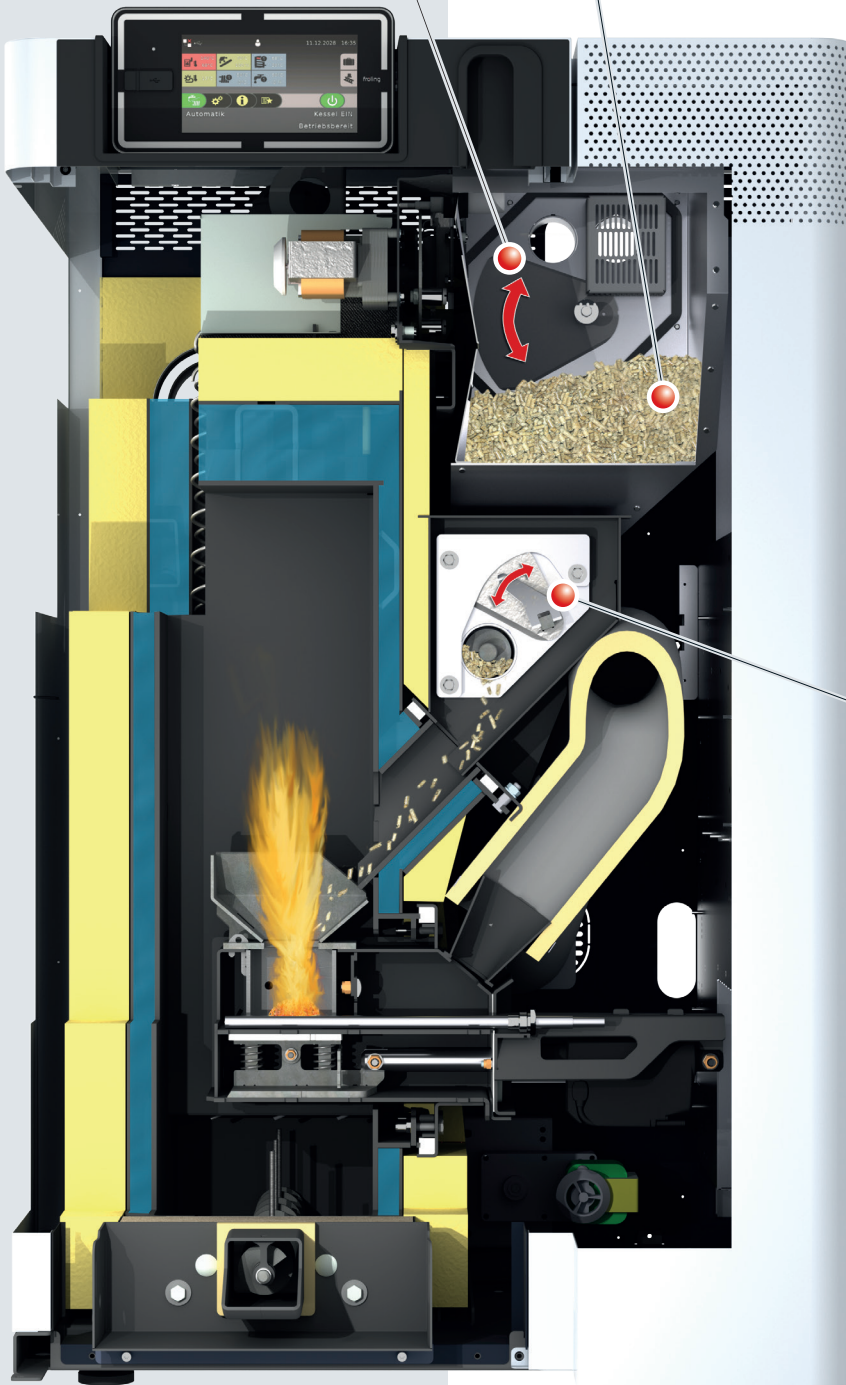

---

# INTELLIGENT FEATURES

---

## Speed-controlled induced draught fan and lambda control with broadband probe

The speed-regulated induced draught fan, which comes as standard, ensures the exact air quantity for combustion. As the induced draught fan is speed-regulated, it stabilises combustion throughout and adjusts the output to requirements. Working together with the lambda control, it ensures optimum combustion conditions. The induced draught fan also runs very quietly and energy efficiently.

- Advantages:
- Maximum ease of use
  - Constant optimisation of combustion

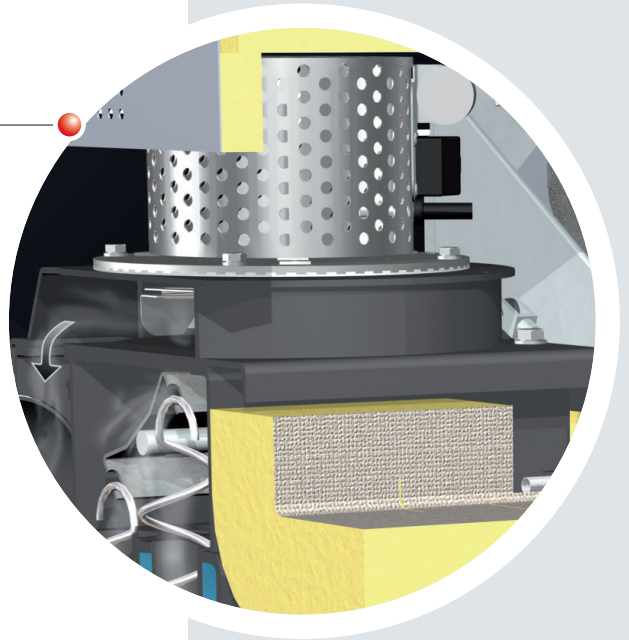

## WOS system as standard

The WOS (Efficiency Optimisation System), which comes as standard, consists of special turbulators, which are placed in the heat exchanger pipes. The lever mechanism is controlled together with the double protection system. An additional benefit: clean heating surfaces ensure higher efficiency and thus lower fuel consumption.

- Advantages:
- Even greater efficiency
  - Fuel savings

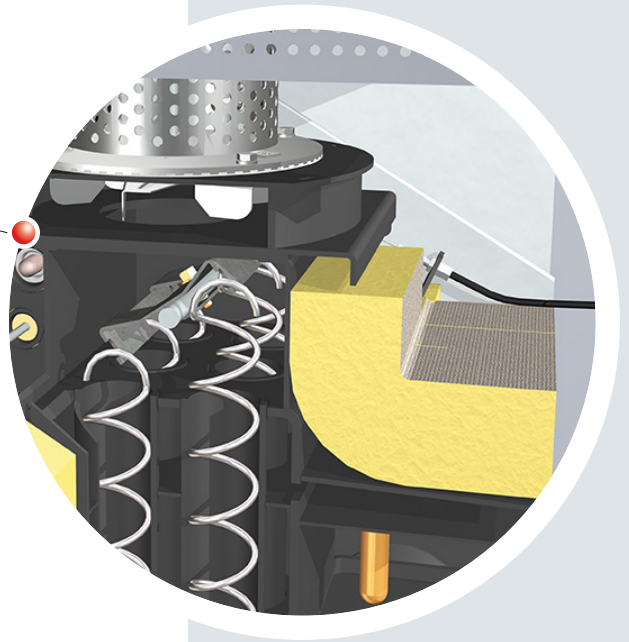



# OPERATING AND MAINTENANCE AREAS

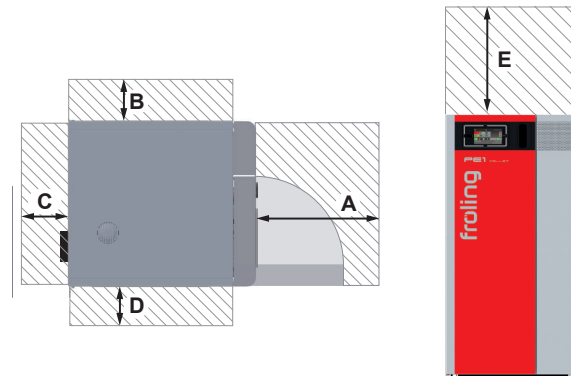

Minimum distances - PE1 Pellet	20	35
A Distance between insulated door and wall	24" (600 mm)	24" (600 mm)
B Distance between side of boiler and wall	12" (300 mm)	12" (300 mm)
C Distance between rear of boiler and wall	12" (300 mm)	12" (300 mm)
D Distance between side of boiler and wall	3.9" (100 mm)	3.9" (100 mm)
E Maintenance area above the boiler <sup>1</sup>	19.7" (500 mm)	19.7" (500 mm)
Minimum space (length x width)	61.2" x 45.2" (1550 x 1150 mm)	61.2" x 45.2" (1550 x 1150 mm)
Minimum room height	70.8" (1800 mm)	78.7" (2000 mm)

<sup>1</sup> Maintenance area to expand the WOS springs upwards

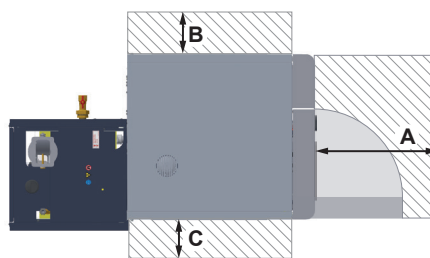

Minimum distances - PE1 Pellet with condensing technology [mm]	20	35
A Distance from insulated door to wall	24" (600 mm)	24" (600 mm)
B Distance from boiler side to wall (control side)	12" (300 mm)	12" (300 mm)
C Distance between side of boiler and wall	3.9" (100 mm)	3.9" (100 mm)
E Maintenance area above the boiler <sup>1</sup>	19.7" (500 mm)	19.7" (500 mm)

<sup>1</sup> Maintenance area to expand the WOS springs upwards

#### 4 probe manual suction system

The RS 4 manual pellet suction system creates more space in your fuel store. Thanks to the fact that the suction probes are flexible in terms of location, it is possible to make optimal use of every room shape. The switchover between suction probes is manual. Rule of thumb: Plan for one suction probe for every 1 m<sup>2</sup> pellet storage area.

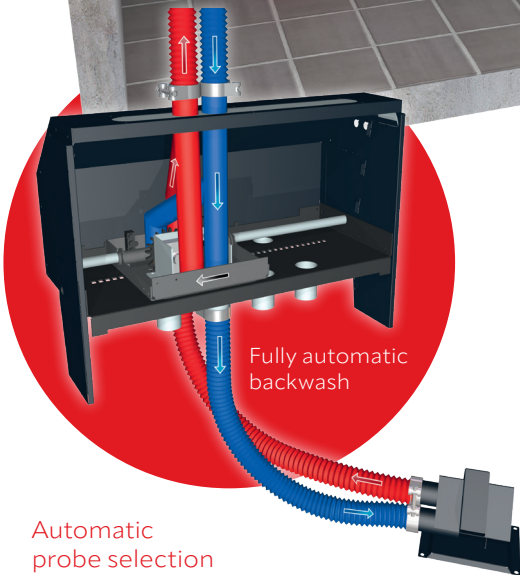

#### External suction module

An external suction module is used for automatic fuel feed from the fuel store to the pellet container. The suction module can be fitted in any position in the return air line.

#### Pellet filler pipes

The pellets are delivered by tanker and blown into the store through a filling pipe. The second pipe is used for controlled and dust free removal of the escaping air.

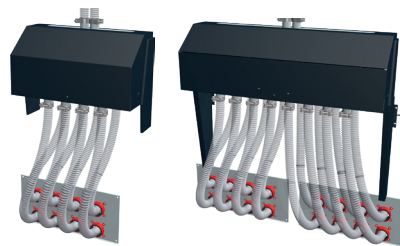

#### Pellet suction system RS 4 / RS 8

Design as above, however with the difference of automatic switchover between the suction probes.

#### Automatic probe selection

It automatically selects 4 or 8 suction probes in specified cycles, it is controlled by the pellet boiler. If, however, the suction probe fails unexpectedly, it is remedied by a fully automatic reversal of the air supply (back flushing).



#### Advantages at a glance:

- easy to assemble
- no sloping slides necessary in the bunker
- more store space (30%)
- automatic switching between the probes
- automatic back flushing
- maintenance-free system

### Bag silo

The bag silo system is a flexible, simple way of storing pellets. Available in 9 different footprints (from 1.5 m x 1.25 m to 2.9 m x 2.9 m) with a capacity of between 1.6 and 7.4 tonnes, depending on the bulk density. There are other advantages to using a bag silo. It is easy to assemble and dustproof. You can also fit rain-proof and sunproof covers and install the silo outside.



### Suction screw system

The Froling screw suction system is the ideal solution for rectangular rooms with front-end removal. The deep and horizontal position of the discharge screw means the space in the room is used optimally and complete emptying of the store is guaranteed. Combined with a suction system from Froling it also enables flexible boiler installation.



### Cube 330/500S pellet supply bin

The Cube 330/500S is the optimal and most cost-effective solution for low fuel requirements. Manually filled (e.g. pellets in sacks) it can store a total of 330 kg/495 kg of pellets. The pellets are transported to the boiler by means of a suction probe, which is also included in delivery.



### Pellet Mole®

This pellet discharge system is easy to install and makes full use of the store space. The Pellet Mole® draws the pellets from above, ensuring an optimum fuel feed to the boiler. The Pellet Mole moves automatically into every corner of the store to empty it as efficiently as possible.



# INDIVIDUAL CONTROL UNIT OF THE HEATING SYSTEM

## Lambdatronic P 3200 control unit

Fröling provides a future-oriented Lambdatronic P 3200 and a new 7" touch display. Intelligent control management makes it possible to connect up to 18 heating circuits, up to 4 storage tanks and up to 8 hot water storage tanks. The control unit ensures that the operating statuses are clearly shown. The menu structure is ideally organised to allow easy operation. All essential functions can be selected by simply pressing icons on the large colour display.

### Advantages:

- Precise combustion control by a Lambda control using a Lambda probe
- Connection for up to 18 heating circuits, 8 water heaters and up to 4 storage tank management systems
- Integration capability for a solar panel system
- LED frame for status display with illuminated presence detection
- Simple and intuitive operation
- Various smart home options (such as Loxone)
- Remote control from the living room (remote control 3200 and RGB 3200 Touch) or via Internet (froeling-connect.com)

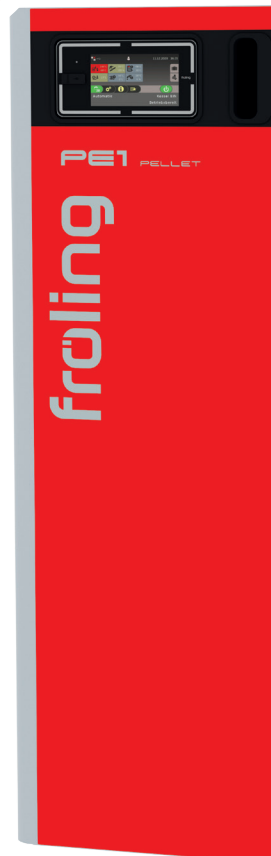

## SIMPLE & INTUITIVE OPERATION

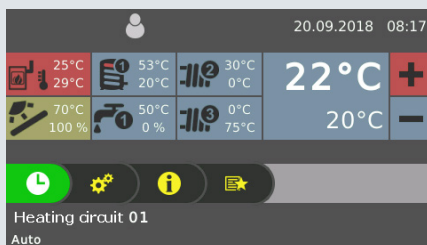

Fig. 1 General overview of the heating circuit (start screen)



Fig. 2 View of the heating times (individually adjustable)

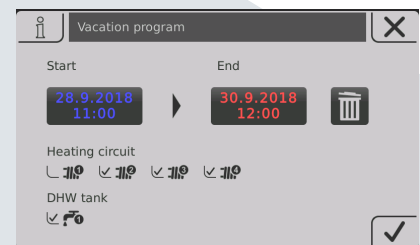

Fig. 3 Overview of the new holiday mode



---

## KEEP TRACK OF EVERYTHING WITH THE FROLING APP

---

The Froling App allows you to check and control your Froling boiler online from anywhere, at any time. You can read and modify the main status information and settings easily and conveniently online. You can also specify which status messages you want to be informed about via SMS or e-mail (e.g. when the ash box is to be emptied or in the event of a fault message).

Froling boiler (software core module from version V50.04 B05.16) with boiler touch display (from version V60.01 B01.34) a broadband internet connection and a tablet/smartphone with iOS or Android operating system are required. Once the boiler has been connected to the internet and activated, the system can be accessed 24/7 from anywhere using a web-enabled device (mobile, tablet, PC, etc.). The app is available in the Android Play Store and iOS App Store.

**NEW! Desktop version  
with even more options.**

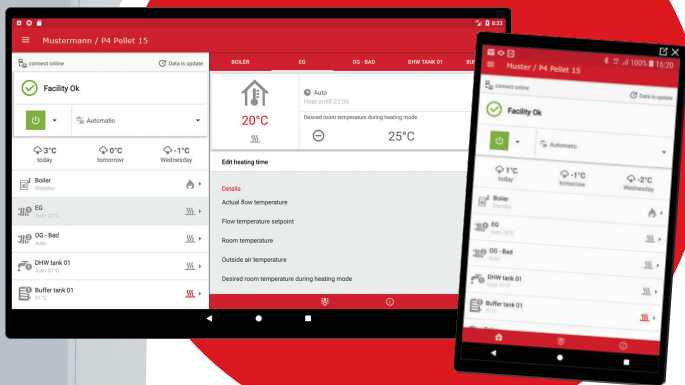

- Simple and intuitive operation of the boiler
- Status information can be called up and changed within seconds
- Individual naming of the heating circuits
- Changes of status are notified directly to the user (e.g. via e-mail or push notifications)
- No additional hardware required (such as an Internet gateway)

---

## SMART HOME

---

Enjoy smart, convenient and piece-of-mind living with the Smart Home connection options from Froling.

### Modbus

Via the Froling modbus interface, the system can be integrated into a building management system.



## ACCESSORIES FOR EVEN GREATER CONVENIENCE

### FRA room temperature sensor

By using the FRA room temperature sensor, sized just 8x8 cm, the main modes of the corresponding heating circuit can be easily selected and adjusted. The FRA can be connected both with and without affecting the store. The adjusting wheel allows you to change the room temperature by up to  $\pm 3^{\circ}\text{C}$ .



### RBG 3200 room console

For even more convenience you can use the RBG 3200 room console and the new RBG 3200 Touch. You can control the heating system easily from your living room. Important system data is clearly displayed and settings can be changed at the push of a button.



### RBG 3200 Touch room console

The RBG 3200 Touch has an impressive touchpad interface. The menu structure means it is intuitive and easy to use. The 17x10 cm console with colour screen shows the most important functions at a glance and automatically adjusts the background lighting to the conditions. The room consoles are connected to the boiler controller using a bus cable.



### Heating circuit module

With wall casing and one contact sensor as heating circuit control for up to two mixer heating circuits.



### Hydraulic module

With wall casing and two immersion sensors to control one or two pumps and one isolating valve with up to six sensors.

Froling systems engineering offers efficient energy management. Up to 4 storage tanks, 8 hot water tanks and 18 heating circuits can help manage the heating. You can also benefit from the ability to integrate other means of energy production such as solar panel systems.

- Advantages:
- Complete solutions for all requirements
  - The components work perfectly together
  - Integrated solar power

# SYSTEMS ENGINEERING FOR OPTIMUM ENERGY CONSUMPTION

PE1 Pellet with buffer tank and gas boiler

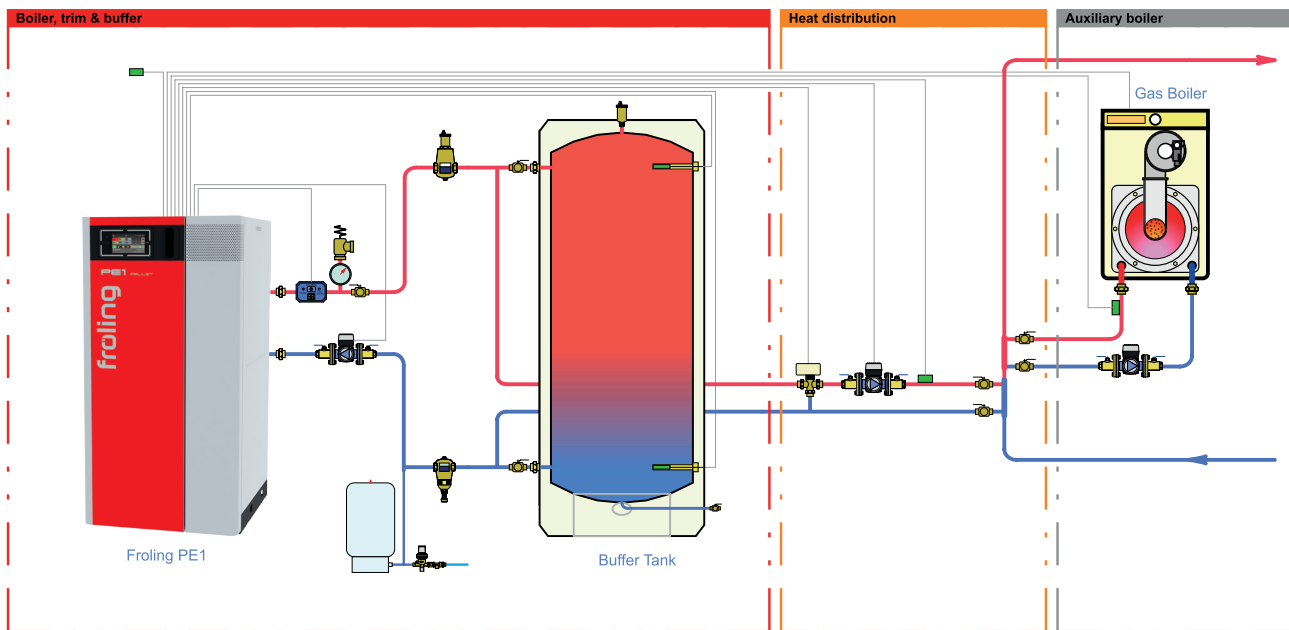

PE1 Pellet with buffer tank and heat pump

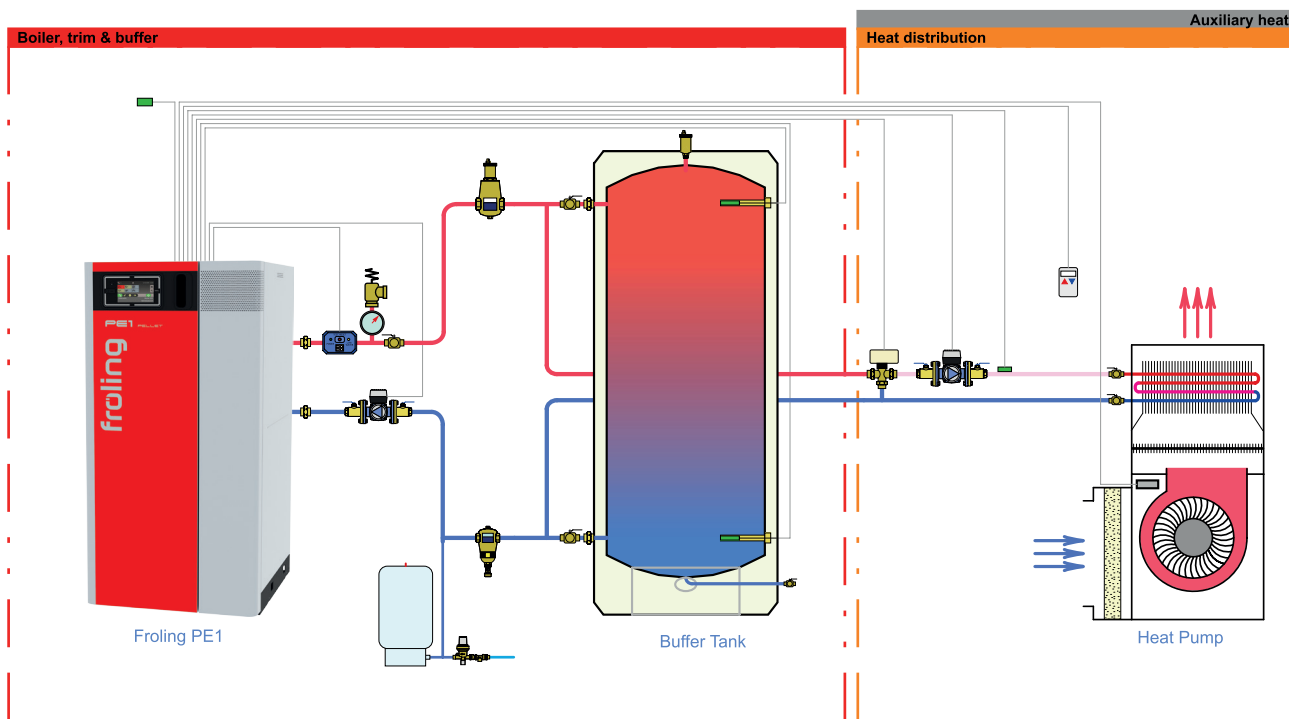

PE1 Pellet cascade with buffer tank

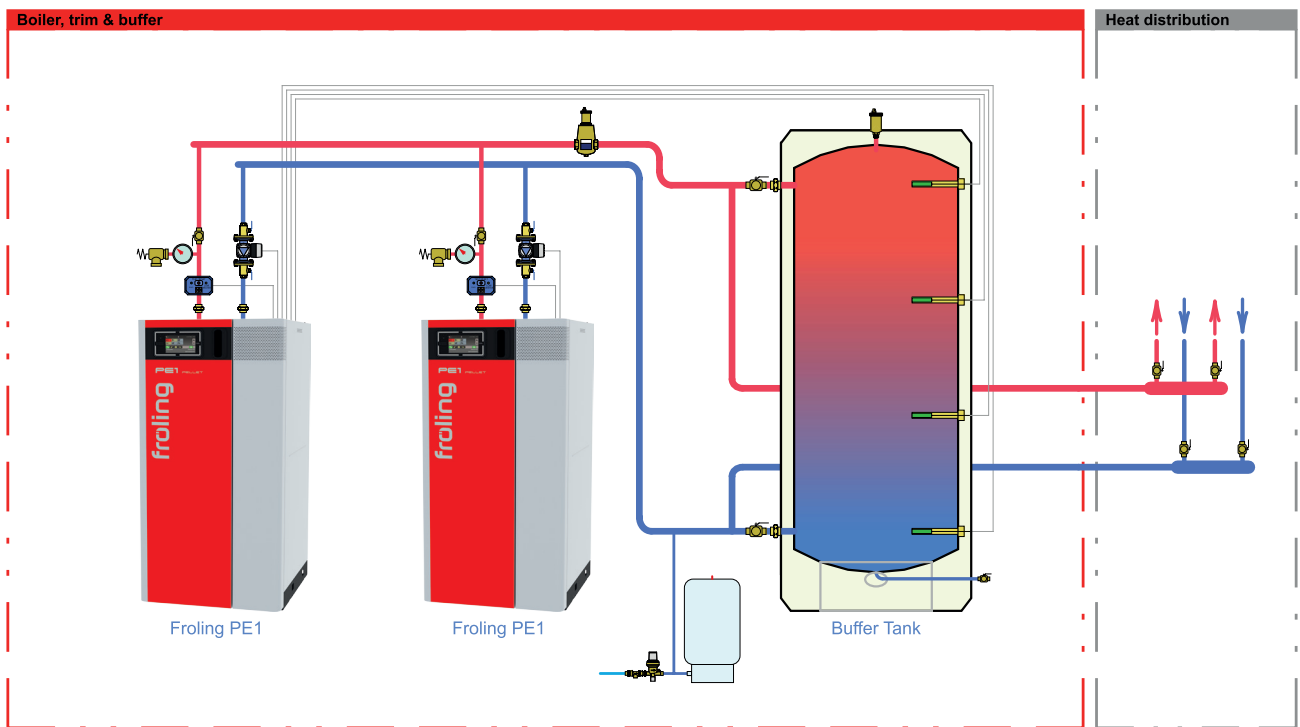

PE1 Pellet with auxiliary boiler

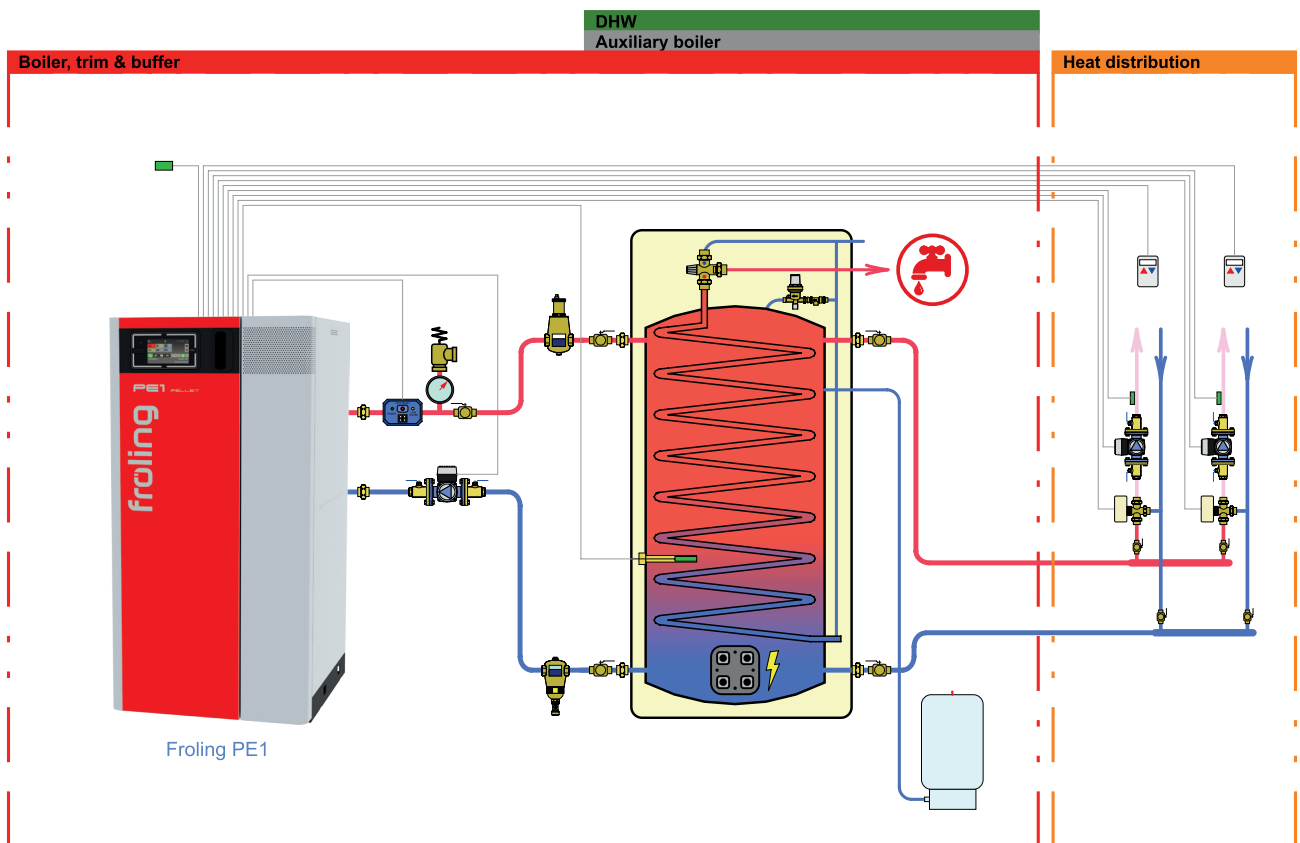



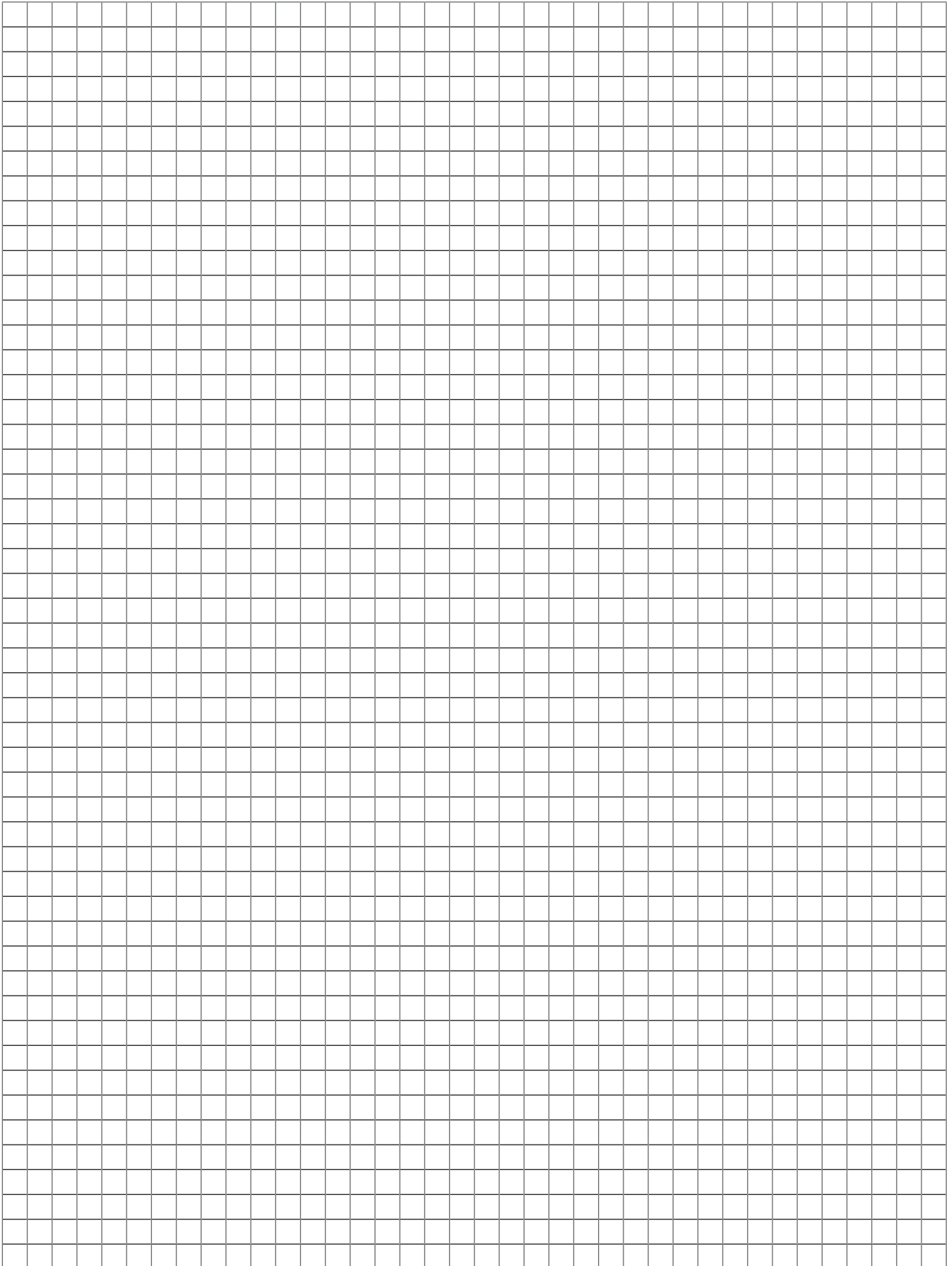

# DIMENSIONS

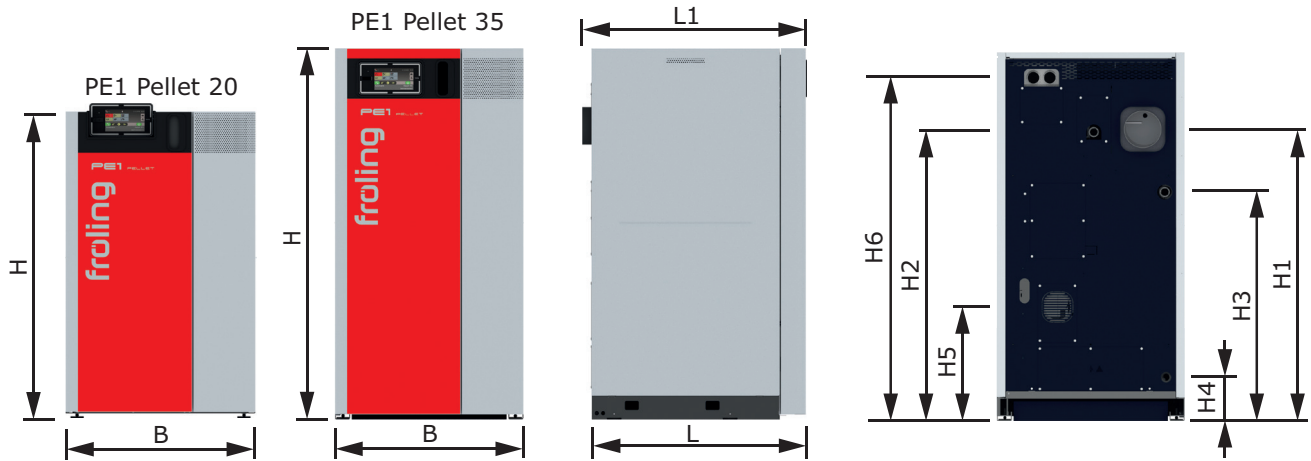

Dimension - PE1 Pellet	20	35
L Length of boiler	27" (690 mm)	33.5" (850 mm)
L1 Total length incl. flue pipe connection	29" (740 mm)	35" (890 mm)
B Width of boiler	29.5" (750 mm)	29.5" (750 mm)
H Height, boiler	49" (1246 mm)	58.3" (1480 mm)
H1 Height, flue pipe connection	36.5" (940 mm)	46" (1170 mm)
H2 Height, flow connection	37" (930 mm)	46" (1160 mm)
H3 Height, return connection	29.5" (750 mm)	36" (920 mm)
H4 Height of drainage connection	4" (95 mm)	7" (175 mm)
H5 Height of supply air connection (for room air-independent operation)	15" (390 mm)	18" (460 mm)
H6 Height of suction system connection	44" (1110 mm)	54" (1380 mm)
Flue gas pipe connection	5" (129 mm)	6" (149 mm)



## TECHNICAL SPECIFICATIONS

Technical data - PE1 Pellet		20	35
Nominal output	Btu/h (kW)	68.200 (20)	119.500 (35)
Output range	Btu/h (kW)	15.300 – 68.200 (4.5 – 20)	24.600 – 119.500 (7.2 – 35)
Electrical connection	[V/Hz/A]	230V / 50Hz / fused C16A	
Boiler weight	lbs (kg)	550 (250)	840 (380)
Total boiler capacity (water)	gal (l)	10 (38)	16 (60)
Pellet container capacity	gal (l)	11 (41)	20 (76)
Ash box capacity	gal (l)	5 (18)	7.4 (28)



### Pellet boiler

PE1 Pellet	15 - 35 kW
P4 Pellet	80 - 100 kW



### Firewood boiler

S3 Turbo	20 - 50 kW
----------	------------



### Wood chip / Large boilers

T4	130 - 150 kW
Turbomat	400 - 500 kW



Vince Rutter (Western Canada)  
 349 Mooney Ave., Thunder Bay, ON  
 Mobile: (807)355-5519 Mail: [vince@biothermic.ca](mailto:vince@biothermic.ca)

Mike Rutter (Eastern Canada)  
 1038 Danmarka Tr., Minden, ON., K0M 2K0  
 Mobile: (705) 455-2314 Mail: [mike@biothermic.ca](mailto:mike@biothermic.ca)



Fröling Heizkessel- und Behälterbau Ges.m.b.H.  
 A-4710 Grieskirchen, Industriestr. 12

AT: Tel +43 (0) 7248 606-0, Fax +43 (0) 7248 606-600  
 Web: [www.froeling.com](http://www.froeling.com)